

EXTERIOR DOOR, SIDELIGHT AND TRANSOM JAMBS

When Pinecrest® is to determine the rough opening size, we make allowances. When you give us the rough opening dimensions, we will make the jamb, door, sidelights, transom and astragal (if specified) to fit those dimensions.

- * **1-1/8" JAMBS ARE REQUIRED FOR THE FOLLOWING:**
- 1-3/4" thick doors with jamb depths of 12" and over (square form doors)
 - 1-3/4" thick doors with jamb depths of 9" and over (arch form doors)
 - 2" and 2-1/4" thick doors regardless of door size and jamb depth.

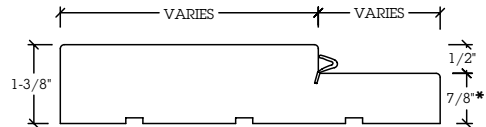

J1 - EXTERIOR DOOR JAMB (single rabbet with kerf)

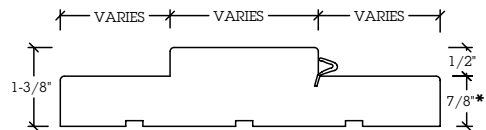

J2 - EXTERIOR DOOR JAMB (double rabbet with kerf)
Must be 5-3/4" or wider. For use with 1-1/8" or 1-3/8" thick screen or storm door. Specify thickness of screen or storm door.

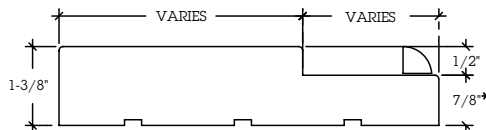

J5 - EXTERIOR SIDELIGHT & TRANSOM (jamb with stop)

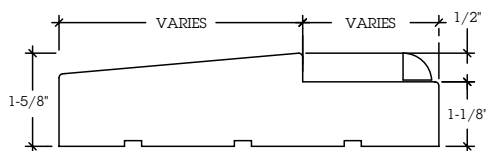

J5 - WOOD SILL FOR SIDELIGHT (with in-swing door)

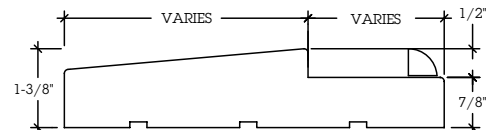

J5 - WOOD SILL FOR TRANSOM (with in-swing door)

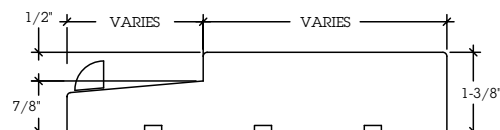

J5 - WOOD SILL FOR SIDELIGHT & TRANSOM (with out-swing door)

NOT TO SCALE

EXTERIOR DOOR ASTRAGALS AND MULLCAPS

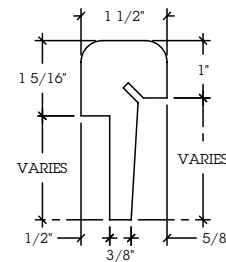

AS1 - KERFED ASTRAGAL

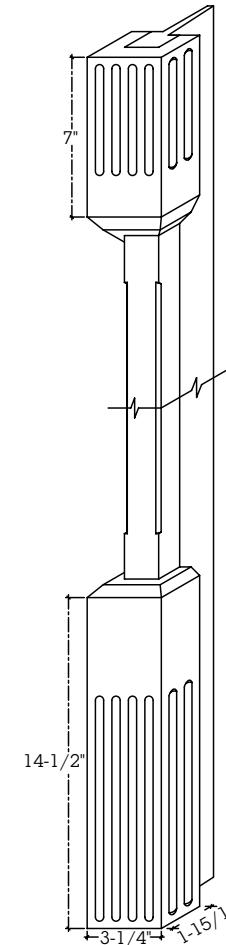

AS30 - KERFED ASTRAGAL

Also see door 98 in the Old World Hand Carved Collection for Astragal AS7 and Door 3078 in the Classic Wood Panel Collection for Kerfed Astragal AS32

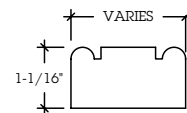

M1 - EXTERIOR MULLCAP

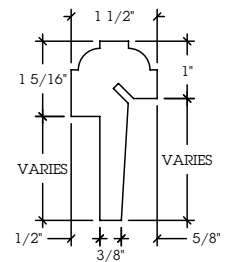

AS4 - KERFED ASTRAGAL

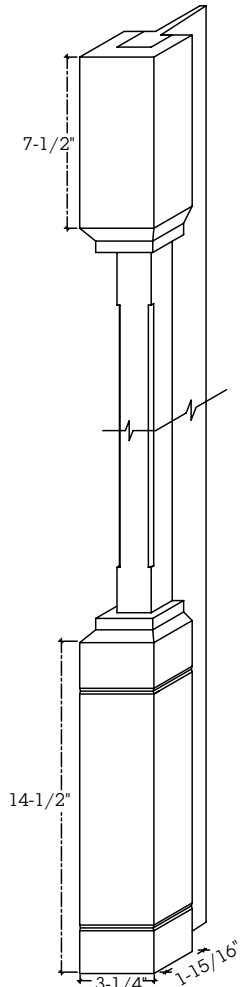

AS31 - KERFED ASTRAGAL

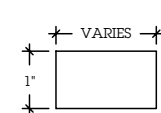

M5 - EXTERIOR MULLCAP

INTERIOR DOOR SIDELIGHT AND TRANSOM JAMBS

When Pinecrest® is to determine the rough opening size, we make allowances. When you give us the rough opening dimensions, we will make the jamb, door, sidelights, transom and astragal (if specified) to fit those dimensions.

Knotty Alder doors will have jambs, mull caps and astragals in Alder (minimal small knots). Distressed Alder (minimal small knots) is available for these items.

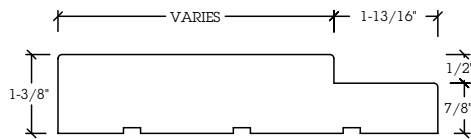

J3 - INTERIOR JAMB (single rabbet)

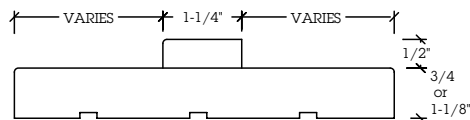

J4 - INTERIOR JAMB (with stop)

INTERIOR MULL CAPS

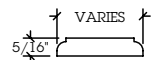

M3 - INTERIOR MULL CAP

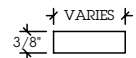

M4 - INTERIOR MULL CAP

INTERIOR ASTRAGALS

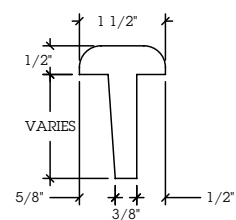

**AS3 - NONKERFED
ASTRAGAL**

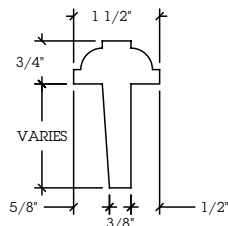

**AS6 - NONKERFED
ASTRAGAL**

Also see door 98 in the Old World Hand Carved section for astragal AS7.

DOOR HINGING PREHUNG EXTERIOR AND INTERIOR DOORS.

1. For single doors specify: B or F (hinge right) or A or E (hinge left).
2. For double doors, which one is to be active, i.e. which one opens first? C or G (right door), D or H (left door). Astragal will be on the inactive door for in swing doors and on the active door for out swing.

Single Doors (In Swing)

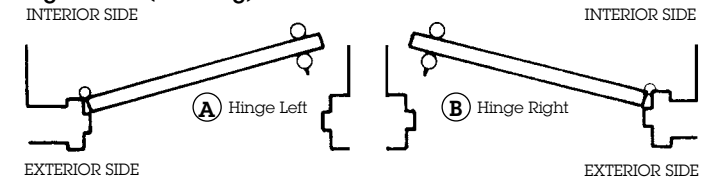

Double Doors (In Swing)

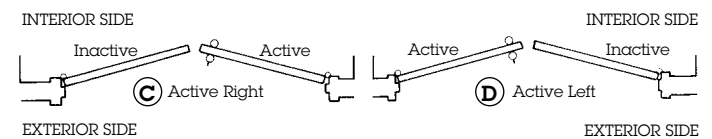

Single Doors (Out Swing)

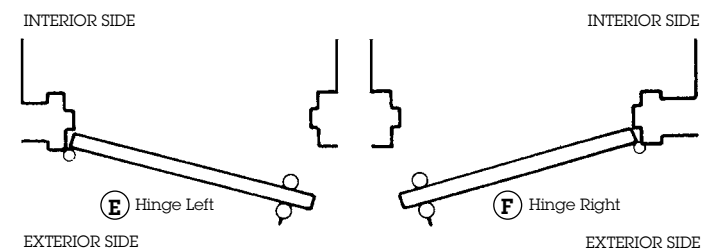

Double Doors (Out Swing)

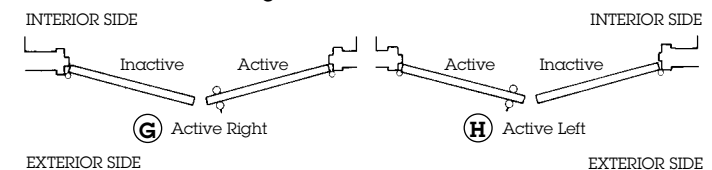

CASING AND BRICKMOULD

Knotty Alder doors will have casing and brickmould in Alder (minimal small knots). Distressed Alder (minimal small knots) is available for these items.

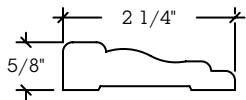

C2 CASING

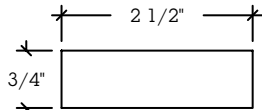

C14 CASING

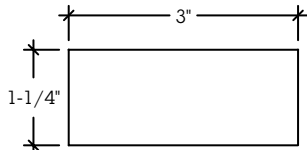

C15 CASING, 1-1/4" T
C15-1 CASING, 3/4" T

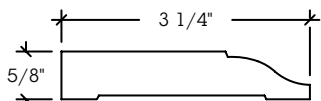

C6 CASING

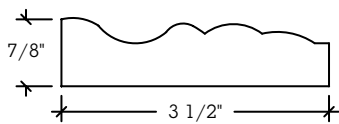

C12 CASING

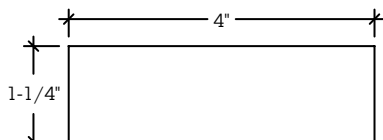

C16 CASING, 1-1/4" T
C16-1 CASING, 3/4" T

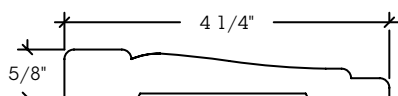

C3 CASING

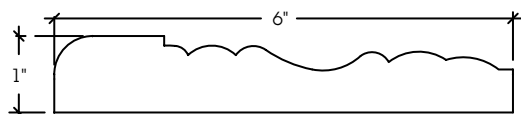

C13 CASING

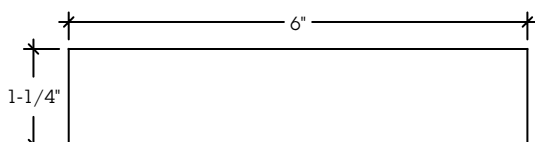

C17 CASING, 1-1/4" T
C17-1 CASING, 3/4" T

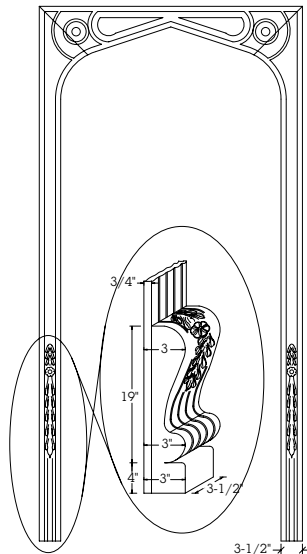

CARVED CASING C7

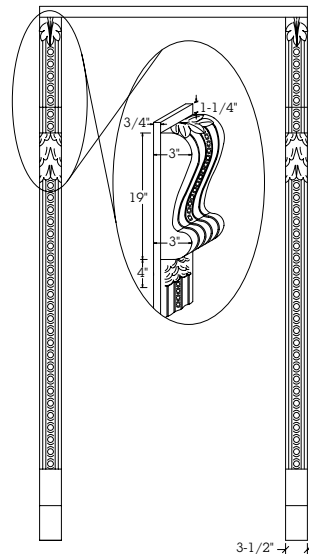

CARVED CASING C8

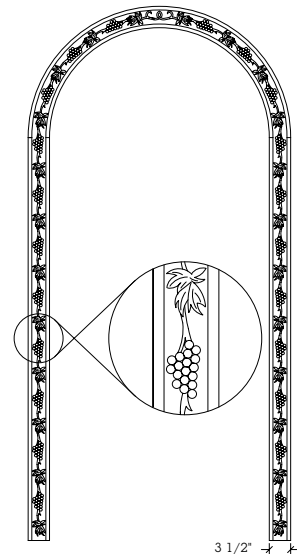

CARVED CASING C9
(ALSO AVAILABLE IN RECTANGULAR FORM.)

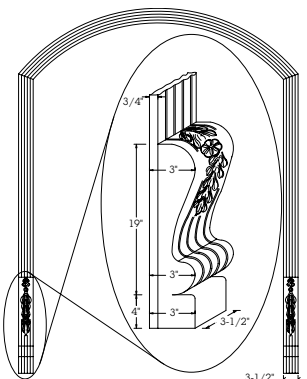

CARVED CASING C10

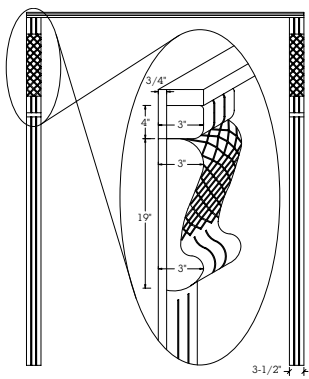

CARVED CASING C11

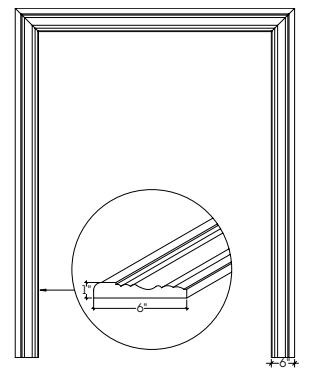

CARVED CASING C13 6"
CARVED CASING C12 3-1/2"
(SEE PROFILES TO LEFT)

SEE DOOR 700 IN THE HAND-WROUGHT IRON COLLECTION (MANORGATE®) FOR CARVED CASING C18 (9-1/2"W)

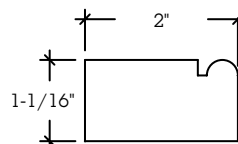

B3 BRICKMOULD

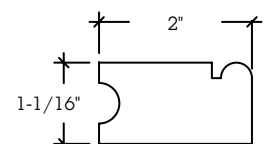

B5 STUCCO BRICKMOULD

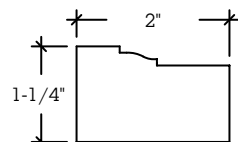

B4 BRICKMOULD

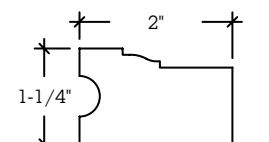

B6 STUCCO BRICKMOULD

NOT TO SCALE